

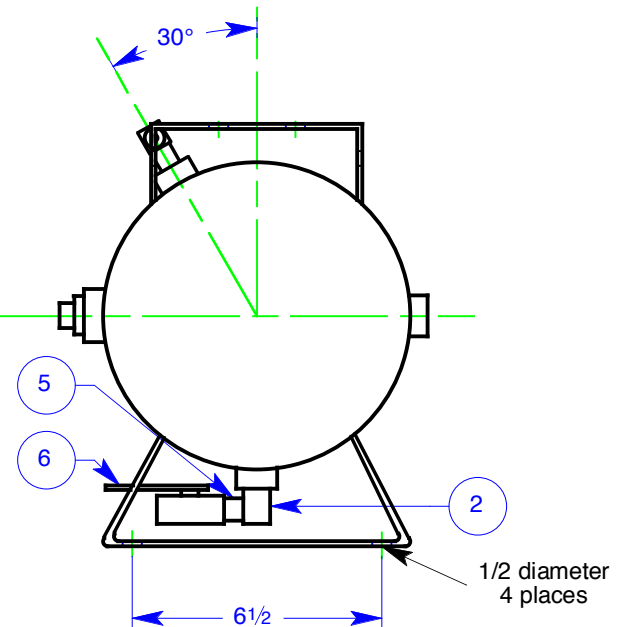

Item	Part Number	Description	Qty.
1	P0252	5.5 Gallon, 600 psi Tank	1
2	1004L01	Street elbow	2
3	1004V01	Relief Valve	1
4	P0003	Logo Label	2
5	1004N01	Nipple	1
6	1004V02	Ball Valve	1

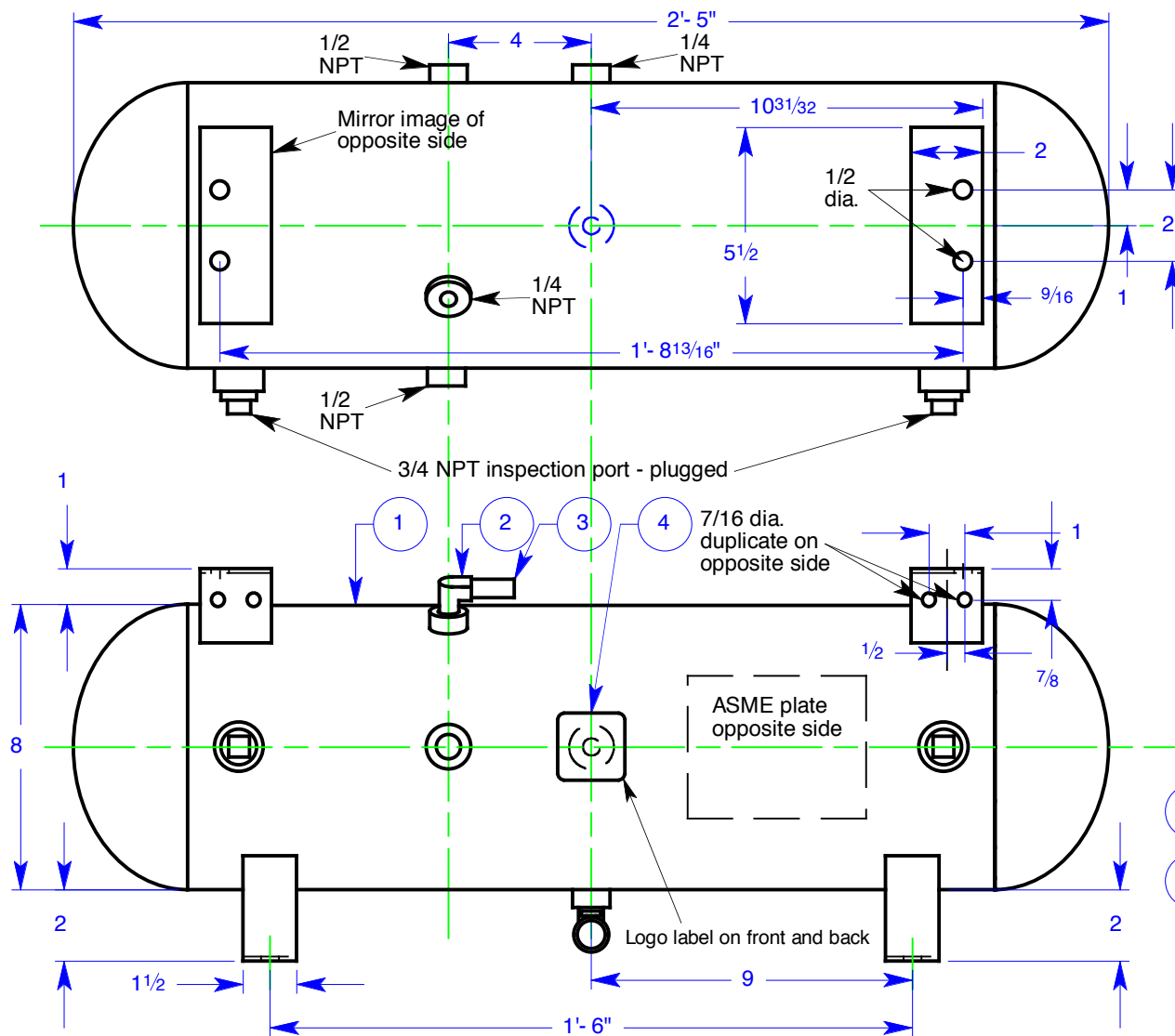

UNLESS OTHERWISE SPECIFIED		SIGNATURES		DATE	 <b>Midwest Pressure Systems, Inc.</b> 1035 Entry Drive, Bensenville, IL 60106
DIMENSIONS ARE IN INCHES TOLERANCES ON: 2 PL DECIMALS +/- 0.01 3 PL DECIMALS +/- 0.003 ANGLES +/- 0.5° FRACTIONS +/- 1/16		DRAWN <b>RAV</b> CHECKED ENGRG ISSUED <b>RAV</b>	DATE <b>1/5/06</b>	DATE <b>1/5/06</b>	
MATERIAL:					DWG NO <b>AA015</b>
				SCALE	SHEET