

Model Number S42N5

5/1 Ratio Gas Pressure Booster System on a 5.5 Gallon Tank

This gas pressure booster system uses shop air to boost the pressure of a shop gas system. The drive air piston reciprocates automatically and drives the gas compressor piston. The booster is unlubricated, and uses filled Teflon® piston seals and rod seals. It requires no electricity, cooling water, or air-line lubricator and is explosionproof.

The maximum discharge pressure is equal to the sum of 4 times the regulated supply air pressure, plus the gas supply pressure. The following graph shows the maximum flowrate capability for a range of shop gas supply pressures and discharge pressures with 80 psi drive air.

The boosted gas flowrate and discharge pressure can be controlled by throttling the drive air flowrate and/or regulating the drive air pressure. When there is no demand for high pressure gas, the booster stalls when it reaches the maximum discharge pressure. When there is a need for high pressure gas the pressure in the discharge line drops which causes the booster to restart automatically.

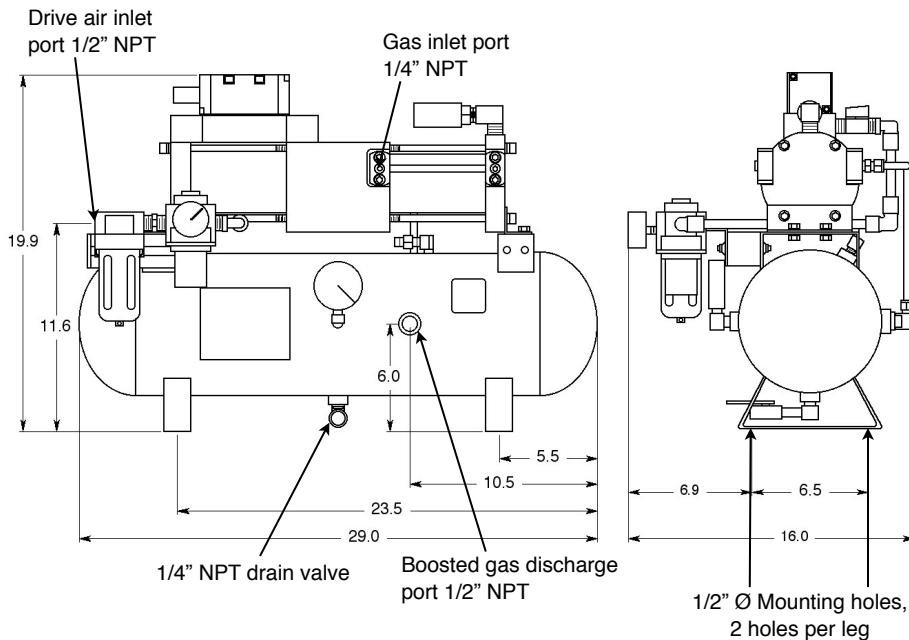

MODEL S42N5 FEATURES

- 1/2" NPT female air inlet port
- 1/2" NPT female gas discharge port
- 1/4" NPT gas inlet port
- 5.5 gallon, 625 psi ASME tank
- 600 psi safety relief valve
- 1/4" NPT drain valve
- 1/2" NPT shop air supply filter
- Shop air pressure regulator
- Regulated air pressure gauge
- Discharge gas pressure gauge
- Exhaust muffler

MODEL S42N5 SPECIFICATIONS

- Capable of 100% duty cycle
- Shop air pressure range of 30-150 psig
- Discharge pressure range of 30-590 psig
- Approximate weight of 81 pounds

MPS
MIDWEST
PRESSURE
SYSTEMS

Midwest Pressure Systems, Inc.
1035 Entry Drive, Bensenville, IL 60106
Phone 630-766-6049 Fax 630-766-6236
www.midwestpressuresystems.com

Gas Pressure Boosting

Drive air pressure is 80 psig - Gas supply pressures from 60 to 100psig

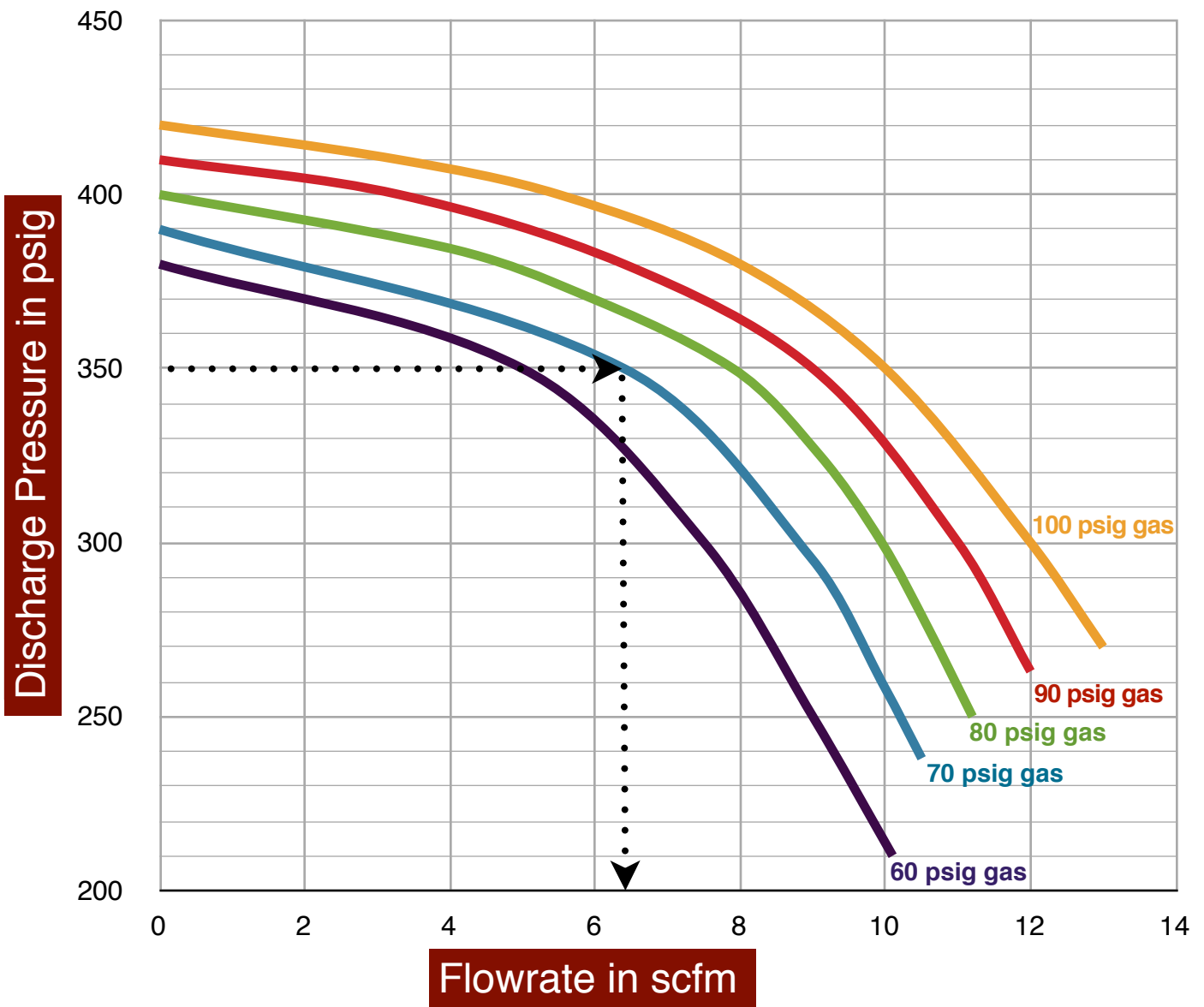

Use the curves above to determine the Model S42N5 gas pressure booster maximum discharge flowrate for a given set of operating conditions. In the example shown above, a maximum discharge pressure of 350 psig is desired. Note that the drive air pressure is 80 psig for all points on the curves. For a gas supply pressure of 70 psig, follow the

350 psig line until it intersects with the 70 psig supply gas curve. Draw a vertical line from the intersection down to the bottom line to determine the maximum flowrate of 6.3 scfm. The booster can operate at any flowrate from zero to the maximum flowrate. It will automatically adjust its operating speed as long as the required flowrate is in this range.



Midwest Pressure Systems, Inc.
1035 Entry Drive, Bensenville, IL 60106
Phone 630-766-6049 Fax 630-766-6236
www.midwestpressuresystems.com

