

Model Number RL03S-D

Bootstrap Compressor • Installation and Operating Instructions

- 1** Mount the Model RL03S-D Bootstrap Compressor on a horizontal surface. Other mounting orientations are not recommended. The booster system vibrates while operating, so use the four 1/2" mounting holes, shown in the diagram to the right, to bolt it to a solid surface.
- 2** Connect your shop air line to the 1/4" FNPT air inlet filter on the front of the booster. A shutoff valve can be installed upstream of the filter for convenient removal of the system for maintenance. The booster has a built-in discharge pressure regulator. Do not install a supply pressure regulator. Lowering the supply pressure reduces the efficiency of the system. The unit is permanently lubricated. **Use of an inlet lubricator will void the warranty. The maximum inlet pressure is 150 psig.**
- 3** Attach discharge line to the 1/2" FNPT ball valve located in front of the receiver tank. **If the application requires a lubricator, make sure the lubricator is installed downstream of the booster.**
- 4** The accumulator tank has a 1/4" ball valve to drain condensate. A drain line or automatic drain valve can be attached to this valve when needed. Close the valve before starting booster.
- 5** The discharge pressure regulator is set by the black, snap-lock knob mounted on the top of the unit. Pull up on the knob to unlock it. Adjust the knob by turning it clockwise for a higher discharge pressure (up to a maximum of 240 psig), or counterclockwise for a lower discharge pressure. Inlet pressure is read on the gauge to the left hand side. The second gauge indicates discharge pressure. Supply shop air to the booster and it will start to operate. Set the regulator to attain the desired discharge pressure, and push down on the regulator knob until it "clicks" to lock the regulator on that setting. The regulator is self-relieving. When the discharge pressure setting on the regulator is reduced, the higher pressure stored in the system will vent through the regulator until pressure equilibrium is reached. **If the inlet pressure is higher than 120 psig, it is possible to set the regulator so the booster exceeds the maximum discharge pressure of 240 psig. Do not operate the booster under these conditions. It is designed to operate continuously at a maximum discharge pressure of 240 psig.**

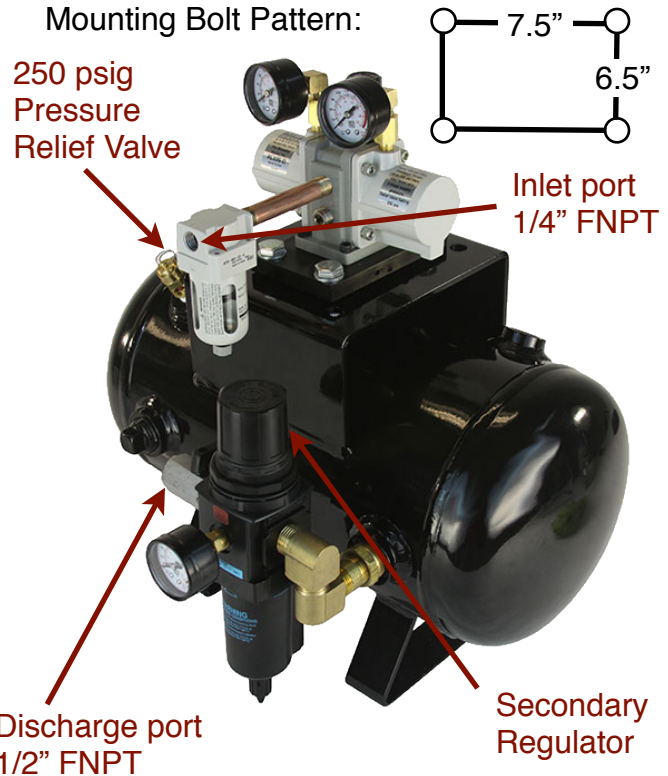

- 6** For maximum high pressure air storage, Bootstrap Compressor's regulator to charge the accumulator to 240 psig. Set the secondary regulator on the discharge line to the desired discharge pressure. This allows for greater accumulator storage capacity, and minimizes pressure fluctuations in the system. Make sure that any downstream components are rated for the accumulator pressure, or are protected by a relief valve in case the secondary regulator fails.
- 7** The Bootstrap Compressor will operate as long as there is demand for high pressure air. When there is no demand, the booster will "stall" at the pressure set by the booster's discharge regulator. The stalled condition consumes no energy and does not damage the booster. The booster will start up automatically when the pressure falls slightly as a result of demand for high
- 8** The accumulator is rated for 350 psig and includes a relief valve set for 250 psig. **This relief valve was selected to prevent operation of the booster above its maximum allowable discharge pressure of 240 psig.**

MPS
MIDWEST
PRESSURE
SYSTEMS

Midwest Pressure Systems, Inc.
850 Transport Drive, Valparaiso, IN 46383
Phone 219-462-0070 Fax 219-318-2277
www.midwestpressuresystems.com

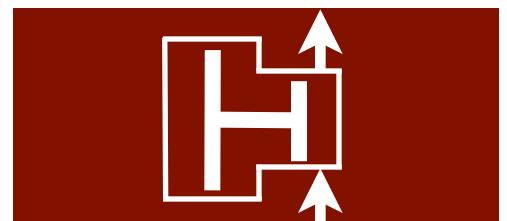

Model Number RL03S

Bootstrap Compressor • Operation and Warranty

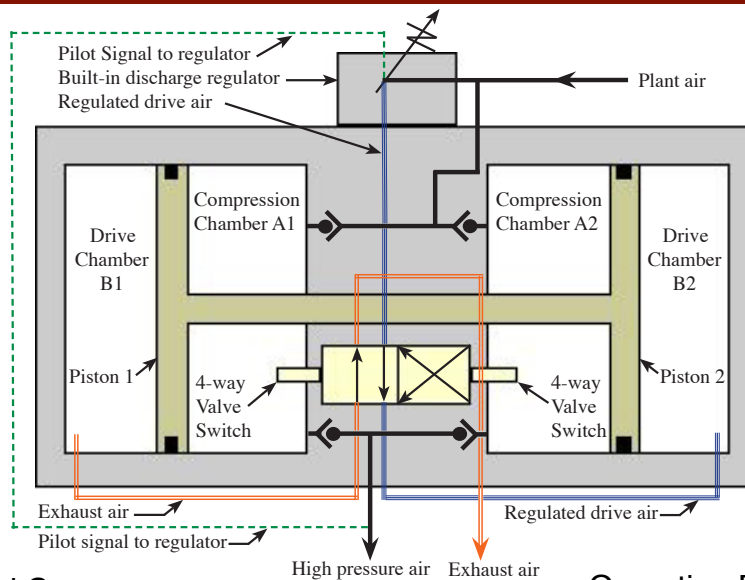

General Concerns

Please refer to the operating description on the right, and the schematic above to gain an understanding of the design principles and mechanical function of the Model RL03S-D Bootstrap Compressor. The moving parts of the Bootstrap Compressor are permanently lubricated with a multipurpose grease (except for the check valves). Operation with a lubricator upstream voids the warranty. If a lubricator is required, it should be installed on the downstream (discharge) side. A well-maintained 5 micron inlet air filter is required to maintain the warranty by ensuring that no dust particles enter the unit and foul the seals, or cause premature wear of the highly-polished seal surfaces. The wear parts in the booster consist of check valves, springs and dynamic seals. These parts are designed for 1800 miles of piston travel. The four-way valve, which controls movement of the pistons, is a lapped, stainless steel valve with no elastomeric seals subject to wear. Under normal conditions, this valve will provide many years of operation. The discharge regulator built into the center of the unit sees very little wear, and is designed to provide many years of service under normal conditions.

Operating Description

The plant air stream always fills Compression Chambers A1 and A2 directly, through a set of check valves. These two chambers are always pressurized to the maximum initial air pressure available (the Model RL03S-D Bootstrap Compressor is not designed for inlet air pressures higher than 150 psig). A branch of the plant air stream flows through a pilot-activated regulator, which reduces the pressure to the level required to attain the desired Bootstrap Compressor discharge pressure (the discharge pressure is set manually by adjusting the regulator handle). This regulated air stream flows through a four-way valve which directs it to Drive Chamber B2. At the same time, the four-way valve opens Drive Chamber B1 to exhaust. The pressure force exerted on the interconnected pistons by the pressures in Drive Chamber B2 and Compression Chamber A1, is sufficient to compress the air in Chamber A2 to a higher pressure (the maximum discharge pressure attainable is two times the plant air pressure). At the end of its travel, Piston 2 switches the four way valve, which opens Drive Chamber B2 to exhaust, and pressurizes Drive Chamber B1 with regulated drive air, thus reversing the direction of the interconnected pistons, until Piston 1 switches the valve back to its original position. The interconnected pistons shuttle back and forth continuously, producing a high pressure air stream, determined by the discharge pressure set on the built-in regulator. The Model RL03S-D is designed to operate at a maximum discharge pressure of 240 psig. Higher discharge pressures, though possible, can result in catastrophic failure of the booster.

WARRANTY

Midwest Pressure Systems, Inc. warrants the Model RL03S-D Bootstrap Compressor to be free of defects in material and workmanship for a period of one year after purchase, except piston seals, rod seals, and check valves which are warranted for six months after purchase. We will either repair or replace a failed unit returned by the customer. No other warranty is expressed or implied. Proof of the purchase date is required. This warranty does not apply to equipment which has been abused, and is voided by use of a lubricator, or failure to use a well-maintained inlet filter. Customer must obtain a return authorization number before shipping the unit to the factory.

MPS
MIDWEST
PRESSURE
SYSTEMS

Midwest Pressure Systems, Inc.
850 Transport Drive, Valparaiso, IN 46383
Phone 219-462-0070 Fax 219-318-2277
www.midwestpressuresystems.com

