

Model Number RL00S

Bootstrap Compressor 2:1 Ratio Air Pressure Booster

The Bootstrap Compressor is an air-driven, air pressure booster. It requires no electricity, cooling water, or air-line lubricator and is explosionproof. Shop air is fed to the inlet port through a filter, and is split into two streams inside the booster. One stream flows to the compressor portion of the unit and is boosted to higher pressure. The other stream drives the compressor portion, and is consumed during booster operation. The drive air stream is regulated to maintain the discharge pressure set by the external regulator handle. Drive air consumption is approximately 1/2 to 1 times the amount of pressure-boosted air. For example, if 2 scfm of high pressure air is required, the Bootstrap Compressor will need 3 to 4 scfm of shop air, and 1 to 2 scfm of that air will be vented through an exhaust silencer. For a given shop air pressure, Model RL00S can deliver high pressure air at any flow rate up to the maximum shown on the flow curves below. The pressure regulator enables the booster to adjust automatically to changes in high pressure air demand or shop air pressure. When there is no demand for high pressure air, the booster stalls at the discharge pressure set by the regulator and consumes no energy. When there is a need for high pressure air, the pressure drops which causes the booster to restart automatically.

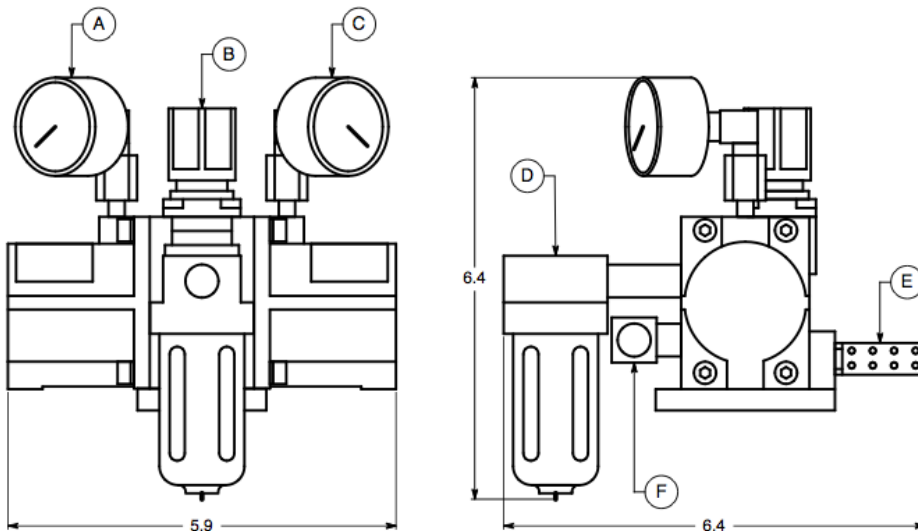

Dimensions are in inches

MODEL RL00S FEATURES

- A. Inlet pressure gauge
- B. Built-in pressure regulator
- C. Discharge pressure gauge
- D. 1/4" FNPT inlet filter
- E. Exhaust Silencer
- F. 1/4" FNPT discharge port

MODEL RL00S SPECIFICATIONS

- Maximum 2 to 1 boost ratio
- Capable of 100% duty cycle
- Inlet pressure range of 15-150 psig
- Discharge pressure range of 15-280 psig
- Temperature range of 40-130°F
- Approximate weight of 6 pounds
- Integral regulator controls discharge pressure and is self-relieving



Midwest Pressure Systems, Inc.
 850 Transport Drive, Valparaiso, IN 46383
 Phone 219-462-0070 Fax 219-318-2277
www.midwestpressuresystems.com

Model RL00S Flowrate vs Supply and Discharge Pressure

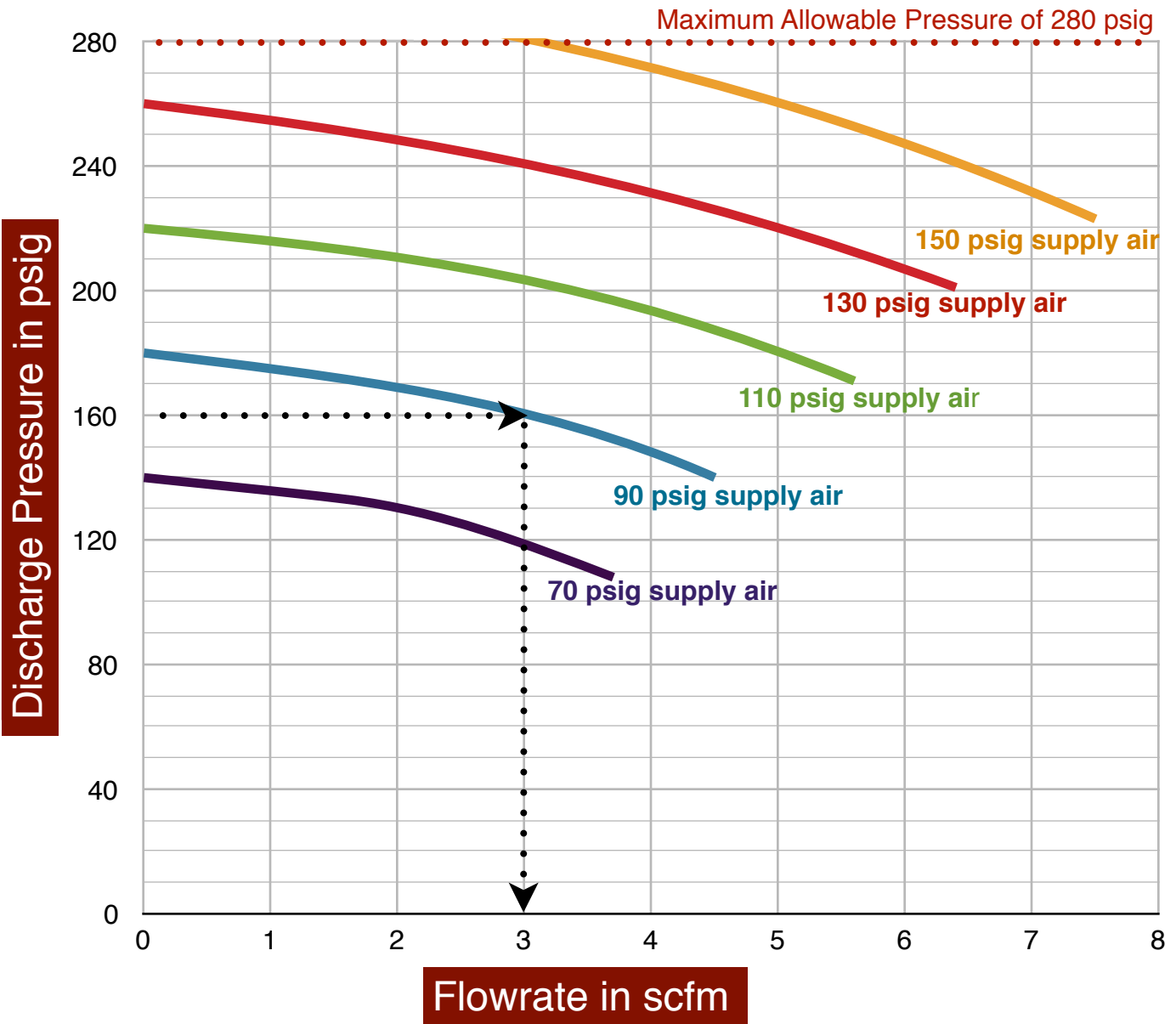

Use the curves above to determine the Model RL00S air pressure booster maximum discharge flowrate for a given set of operating conditions. In the example shown above, a maximum discharge pressure of 160 psig is desired and 90 psig supply air is available. Follow the 160 psig line until it intersects with the

90 psig supply air curve. Draw a vertical line from the intersection down to the bottom line to determine the maximum flowrate of 3.0 scfm. The booster can operate at any flowrate from zero to the maximum flowrate. It will automatically adjust its operating speed as long as the required flowrate is in this range.



Midwest Pressure Systems, Inc.
 850 Transport Drive, Valparaiso, IN 46383
 Phone 219-462-0070 Fax 219-318-2277
www.midwestpressuresystems.com

