

Model Number R12D

Bootstrap Compressor • Installation and Operating Instructions

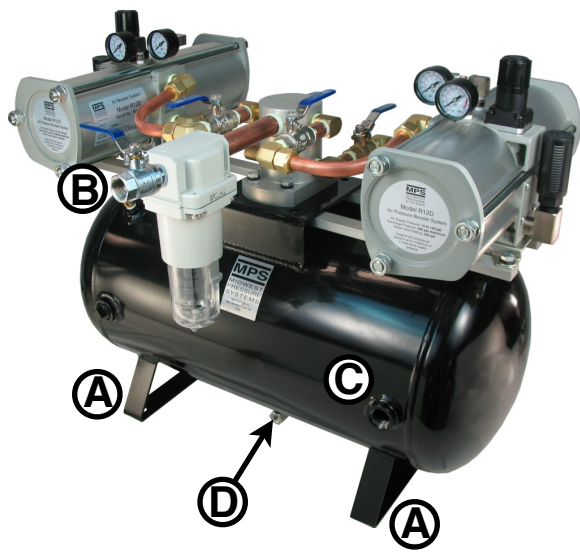

Installation

- 1) Bolt the tank to the floor using the four 1/2 inch diameter mounting holes (A).
- 2) Connect your drive air supply to the 3/4 inch NPT inlet port located on the ball valve, shown above (B). The air supply piping should be 3/4 inch pipe diameter or larger.
- 3) Connect your discharge line to the 3/4 inch NPT pipe port shown above (C). There are several other plugged ports on the tank that can be used for the discharge line. **Make sure that your discharge piping components are rated for 230 psi.**
- 4) Attach your condensate drain line to the 1/4 NPT port on the valve shown above (D).

Startup

- 1) This system can be operated with one or both boosters. To operate with both boosters, open both inlet (E) and discharge valves (F). The discharge valves are on the back side of the tank in the picture above. To operate with one booster, close the inlet and discharge valves of the idle booster.
- 2) There is a discharge pressure regulator for each booster. Pull up on the black knob on the top of the booster to unlock it. Turn the knob clockwise for a higher discharge pressure and counterclockwise for a lower pressure.

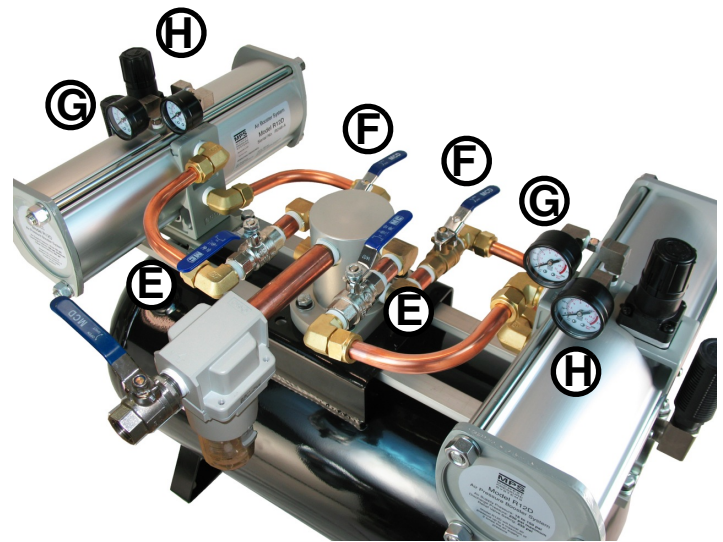

Startup continued

- 3) If both boosters are operating, set both regulators for the same discharge pressure. The regulators are self relieving so if one is set for a higher pressure, the other regulator will try to vent the pressure. The pressure gauges marked (G) indicate inlet pressure and the gauges marked (H) indicate discharge pressure.
- 4) When the boosters have pressurized the tank to the maximum desired pressure, they will stall. If one of the regulators vents at the stall condition, turn the knob clockwise until the venting stops. The maximum recommended discharge pressure is 230 psi. The relief valve is set for 235 psi. If the supply pressure is higher than 115 psi, it is possible to set the regulators so the system exceeds the maximum discharge pressure of 230 psi. During startup, do not turn the regulators to their highest setting, but slowly increase the regulator settings until the desired pressure is reached.

Operation

The system is fully automatic. When the desired discharge pressure has been reached, and no flow is required, the boosters will stop automatically. They will restart when the pressure drops about 5 psi.

Maintenance

The air supply filters and condensate drain should be checked periodically. If a booster needs to be removed for service, close the air supply valve and the discharge valve. The discharge valve will vent the pressure between the two valves and the booster pressure gauges should both read zero. The booster can safely be removed and repaired while the system continues to operate.

MPS
MIDWEST
PRESSURE
SYSTEMS

Midwest Pressure Systems, Inc.
850 Transport Drive, Valparaiso, IN 46383
Phone 219-462-0070 Fax 219-318-2277
www.midwestpressuresystems.com

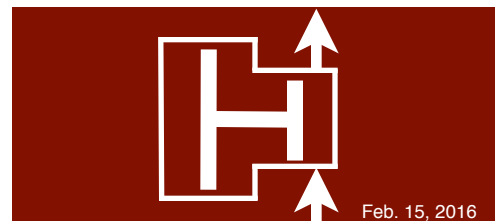

Feb. 15, 2016

Model Number R12D

Bootstrap Compressor • Operation and Warranty

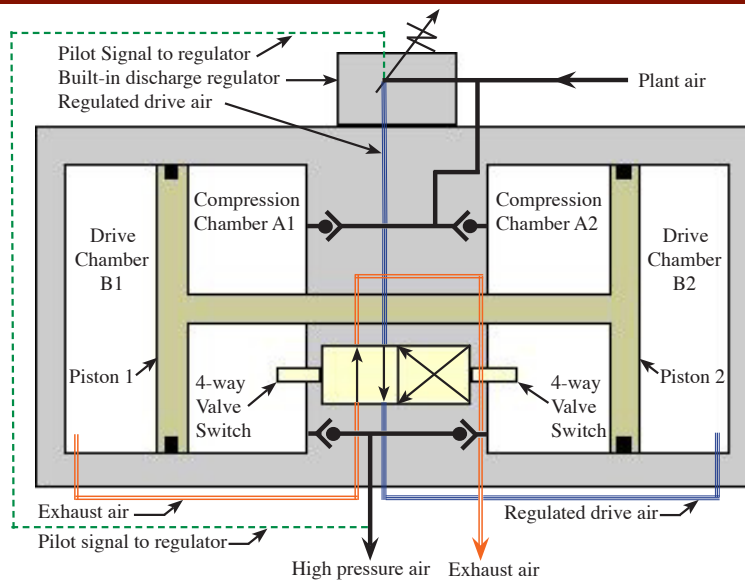

General Concerns

Please refer to the operating description on the right, and the schematic above to gain an understanding of the design principles and mechanical function of the R12D Model Booster System. The moving parts of each Bootstrap Compressor are permanently lubricated with a multipurpose grease (except for the check valves). Operation with a lubricator upstream voids the warranty. If a lubricator is required, it should be installed on the downstream (discharge) side. A well-maintained 5 micron inlet air filter is required to maintain the warranty by ensuring that no dust particles enter the units and foul the seals, or cause premature wear of the highly-polished seal surfaces. The wear parts in the boosters consist of check valves, springs and dynamic seals. These parts are designed for 1800 miles of piston travel. The four-way valve, which controls movement of the pistons, is a lapped, stainless steel valve with no elastomeric seals subject to wear. Under normal conditions, this valve will provide many years of operation. The discharge regulator built into the center of the unit sees very little wear, and is designed to provide many years of service under normal conditions. The wear parts are typically replaced 2 to 3 times before a valve or regulator kit is required.

#KRW • Wear parts kit

#KRV • Valve kit

#KRR • Regulator kit

Operating Description

The plant air stream always fills Compression Chambers A1 and A2 directly, through a set of check valves. These two chambers are always pressurized to the maximum initial air pressure available (the R12D Model Booster System is not designed for inlet air pressures higher than 150 psig). A branch of the plant air stream flows through a pilot-activated regulator, which reduces the pressure to the level required to attain the desired Bootstrap Compressor discharge pressure (the discharge pressure is set manually by adjusting the regulator handle). This regulated air stream flows through a four-way valve which directs it to Drive Chamber B2. At the same time, the four-way valve opens Drive Chamber B1 to exhaust. The pressure force exerted on the interconnected pistons by the pressures in Drive Chamber B2 and Compression Chamber A1, is sufficient to compress the air in Chamber A2 to a higher pressure (the maximum discharge pressure attainable is two times the plant air pressure). At the end of its travel, Piston 2 switches the four way valve, which opens Drive Chamber B2 to exhaust, and pressurizes Drive Chamber B1 with regulated drive air, thus reversing the direction of the interconnected pistons, until Piston 1 switches the valve back to its original position. The interconnected pistons shuttle back and forth continuously, producing a high pressure air stream, determined by the discharge pressure set on the built-in regulator. The R12D Model is designed to operate at a maximum discharge pressure of 230 psig. Higher discharge pressures, though possible, can result in catastrophic failure of the booster.

WARRANTY

Midwestern Pressure Systems, Inc. warrants the R12D Model Booster System to be free of defects in material and workmanship for a period of one year after purchase, except piston seals, rod seals, and check valves which are warranted for six months after purchase. We will either repair or replace a failed unit returned by the customer. No other warranty is expressed or implied. Proof of the purchase date is required. This warranty does not apply to equipment which has been abused, and is voided by use of a lubricator, or failure to use a well-maintained inlet filter. Customer must obtain a return authorization number before shipping the unit to the factory.

MPS
MIDWEST
PRESSURE
SYSTEMS

Midwest Pressure Systems, Inc.

850 Transport Drive, Valparaiso, IN 46383

Phone 219-462-0070 Fax 219-318-2277

www.midwestpressuresystems.com



Feb. 15, 2016