

Model Number R00D

2:1 Maximum Pressure Boost

Supply Pressure of 15 to 150 psig

Self-Relieving Maximum Discharge Pressure Regulator

Discharge Pressure of 15 to 230 psig

Temperature Range of 40-130 °F

100% Duty Cycle

Approximate Weight of 55 Pounds

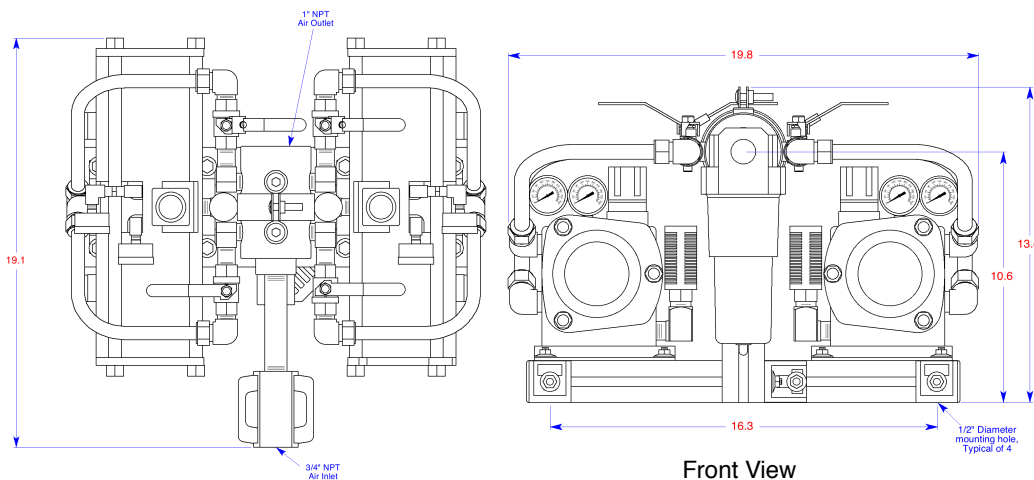
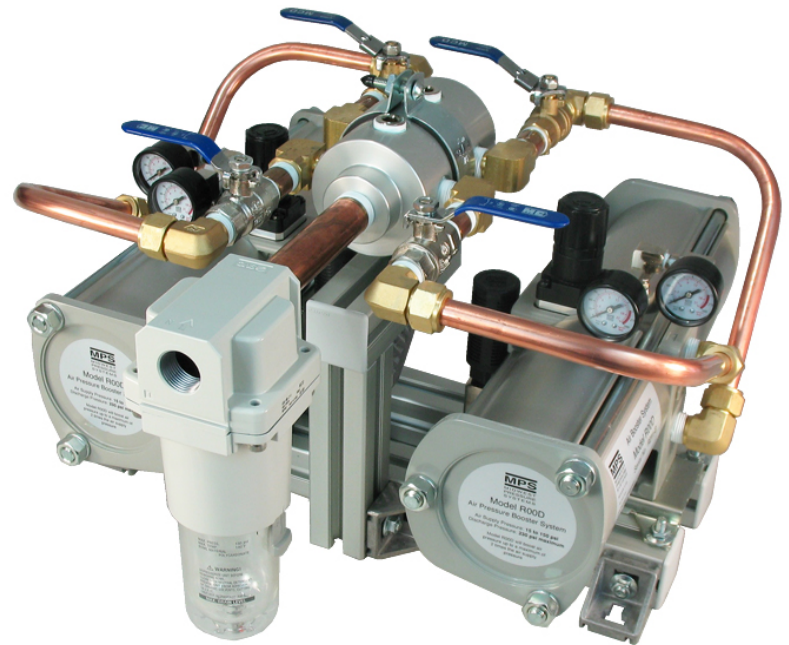

Top View

Front View

Dimensions are in inches.

MODEL R00D FEATURES

- A. Inlet pressure gauge
- B. Built-in pressure regulator
- C. Discharge pressure gauge
- D. 3/4" FNPT inlet filter
- E. Exhaust silencer
- H. 3/4" FNPT discharge port
- I. 1/4" FNPT condensate drain valve
- J. Four 1/2" diameter mounting holes
- K. 1/2" FNPT booster shutoff valve
- L. 1/2" FNPT safety vent valve
- M. 3/4" FNPT air inlet shutoff valve

MPS
MIDWEST
PRESSURE
SYSTEMS

Midwest Pressure Systems, Inc.
850 Transport Drive, Valparaiso, IN 46383
Phone 219-462-0070 Fax 219-318-2277
www.midwestpressuresystems.com

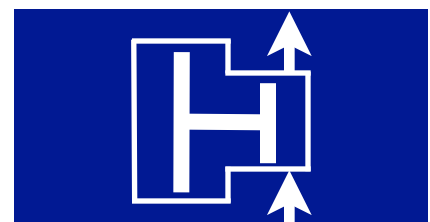

Model R00D Flowrate vs Supply and Discharge Pressure

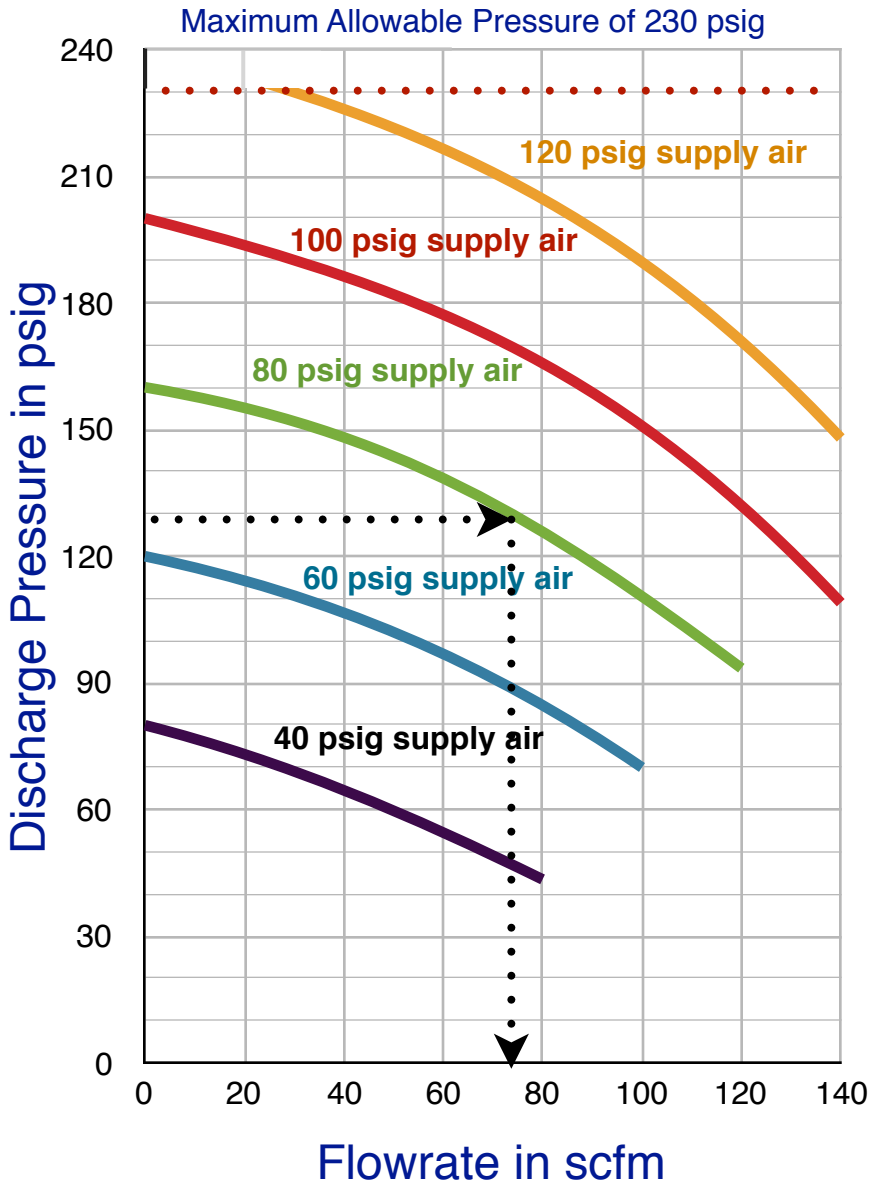

Reading the Graph

Use the curves to the left to determine the Model R00D air pressure booster maximum discharge flowrate for a given set of operating conditions. In the example shown above, a maximum discharge pressure of 130 psig is desired and 80 psi supply air is available. Follow the 130 psi line until it intersects with the 80 psi supply air curve. Draw a vertical line from the intersection down to the bottom line to determine the maximum flowrate of 74 scfm. The booster can operate at any flowrate from zero to the maximum flowrate. It will automatically adjust its operating speed as long as the required flowrate is in this range.

Specifications and Operation

The Bootstrap Compressor is an air-driven, air pressure booster. It requires no electricity, cooling water, or air-line lubricator and is explosionproof. Shop air is fed to the inlet port through a filter, and is split into two streams inside the booster. One stream flows to the compressor portion of the unit and is boosted to higher pressure. The other stream drives the compressor portion, and is consumed during booster operation. The drive air stream is regulated to maintain the discharge pressure set by the external regulator handle. Drive air consumption is approximately 1/2 to 1 times the amount of

pressure-boosted air. For example, if 10 scfm of high pressure air is required, the Bootstrap Compressor will need 15-20 scfm of shop air, and 5-10 scfm of that air will be vented through an exhaust silencer. For a given shop air pressure, Model R00D can deliver high pressure air at any flowrate up to the maximum shown on the flow curves below. The pressure regulator enables the booster to adjust automatically to changes in high pressure air demand or shop air pressure. When there is no demand for high pressure air, the booster stalls at the discharge pressure set by the regulator and consumes no energy. When there is a need for high pressure air, the tank pressure drops which causes the booster to restart automatically.

The R00D can be operated using a single booster or both boosters in unison. During single booster operation the idle booster can be completely isolated and depressurized allowing it to be removed from the system for maintenance.



Midwest Pressure Systems, Inc.
 850 Transport Drive, Valparaiso, IN 46383
 Phone 219-462-0070 Fax 219-318-2277
www.midwestpressuresystems.com

