

Model AC002 Bootstrap Compressor

Increase Shop Air Pressure

2:1 Maximum Pressure Boost Ratio

280 psi Maximum Discharge Pressure



The Bootstrap Compressor is an air-driven, air pressure booster. It requires no electricity, cooling water, or air-line lubricator and is explosionproof. Shop air is fed to the inlet port through a filter, and is split into two streams inside the booster. One stream flows to the compressor portion of the unit and is boosted to higher pressure. The other stream drives the compressor portion, and is consumed during booster operation. The drive air stream is regulated to maintain the discharge pressure set by the external regulator handle. Drive air consumption is approximately 1/2 to 1 times the amount of pressure-boosted air. For example, if 4 scfm of high pressure air is required, the Bootstrap Compressor will need 6-8 scfm of shop air, and 2-4 scfm of that air will be vented through an exhaust silencer. For a given shop air pressure, Model AC002 can deliver high pressure air at any flowrate up to the maximum shown in the table. The pressure regulator enables the booster to adjust automatically to changes in high pressure air demand or shop air pressure. When there is no demand for high pressure air, the booster stalls at the discharge pressure set by the regulator and consumes no energy. When there is a need for high pressure air, the pressure drops which causes the booster to restart automatically.

Shop Air psi	Maximum Flowrate in scfm						
	Discharge Pressure in psi						
	90	100	110	120	150	200	250
70	4	3	3	2	0	0	0
80	5	5	5	3	1	0	0
90		6	6	5	3	0	0
100			7	6	5	0	0
125					9	5	0
150						9	5

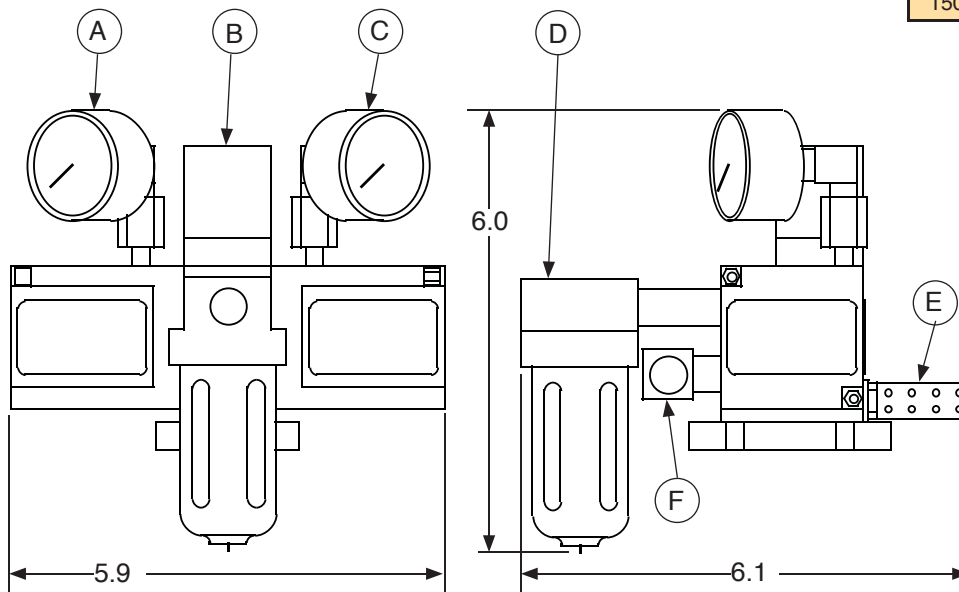

MODEL AC002 FEATURES

- A. Discharge pressure gauge
- B. Built-in pressure regulator
- C. Inlet pressure gauge
- D. 1/4" FNPT inlet filter
- E. Exhaust silencer
- F. 1/4" FNPT discharge port

MODEL AC002 SPECIFICATIONS

- Maximum 2 to 1 boost ratio
- Capable of 100% duty cycle
- Inlet pressure range of 15-150 psig
- Discharge pressure range of 15-280 psig
- Temperature range of 40-130°F
- Approximate weight of 6 pounds
- Integral regulator controls discharge pressure and is self-relieving

Dimensions are in inches. Dimensions, features and specifications shown in this brochure are subject to change without notice.



Midwest Pressure Systems, Inc.
204 Easy Street
Carol Stream, IL 60188

Phone 630-933-9037
Fax 630-933-9040
www.midwestpressuresystems.com



Manufacturer of Air and Gas Pressure Booster Systems