

| Item | Part Number | Description | Qty. |
|------|-------------|--|------|
| 1 | P0010 | 3.5 gal ASME receiver tank, 350 psi | 1 |
| 2 | 1004L01 | 1/4 NPT Street elbow | 2 |
| 3 | 1004V24 | 1/4 NPT, 350 psi relief valve, ASME | 1 |
| 4 | P0253 | Mounting plate, 316 SS | 1 |
| 5 | 1106L02 | 3/8 Tube by 1/2 NPT elbow | 1 |
| 6 | 4020AAV48 | Pressure booster, 5:1 boost ratio | 1 |
| 7 | 1306C035 | 3/8"OD by .035 wall tubing, copper | 1 |
| 8 | 1008P01 | 1/2" NPT Hex plug, br | 2 |
| 9 | 1108L05 | 1/2 tubing to 1/2 tubing push-lock elbow | 1 |
| 10 | 1308N062 | 1/2 Nylon tubing, .062 wall | 2 |
| 11 | 2135S01 | M10 Screw, 35 mm, hexhead | 4 |
| 12 | 2110W01 | M10 Flat washer | 4 |
| 13 | 1006V02 | 3/8 NPT valve, mini-ball, 450 WOG | 1 |
| 14 | 1108A03 | 1/2 tube by 3/8 NPT elbow, br | 1 |
| 15 | P0003 | Product label, D0008-23 | 1 |
| 16 | 1008R01 | 1/2 NPT Regulator | 1 |
| 17 | 1108A02 | 1/2 MNPT by 1/2 tube elbow | 3 |
| 18 | 1004G02 | 160 psi gauge | 1 |
| 19 | 1008N01 | 1/2 NPT Nipple, hex | 1 |
| 20 | 1008T03 | 1/2 NPT Run tee | 1 |
| 21 | 1008F02 | 1/2 NPT Filter | 1 |
| 22 | 1004G04 | 1/4 NPT, 600 psi Pressure gauge | 1 |
| 23 | P0003 | MPS logo label | 1 |
| 24 | 1004V13 | Vent Valve | 1 |
| 25 | 1108A11 | 3/8" Tube by 3/8" NPT Union, br | 1 |
| 26 | 1012B03 | 3/4" NPT by 3/8" NPT Bushing | 1 |
| 27 | 1006T02 | 3/8 NPT Run tee | 1 |
| 28 | 1012B02 | 3/4 MNPT by 1/4 FNPT Bushing | 1 |
| 29 | 2016N02 | 1/4-20 Nut | 2 |
| 30 | 2016W01 | 1/4 Lockwasher | 2 |
| 31 | 2016B02 | Filter mounting bracket | 1 |
| 32 | 2016W02 | 1/4 Flat washer | 2 |
| 33 | 2016S03 | 1/4-20 Hex cap screw | 2 |
| 34 | 2110W02 | Lockwasher | 4 |
| 35 | 2110N01 | Nut | 4 |

| REVISIONS | | | |
|-----------|-------------|------|----------|
| REV | DESCRIPTION | DATE | APPROVED |
| | | | |

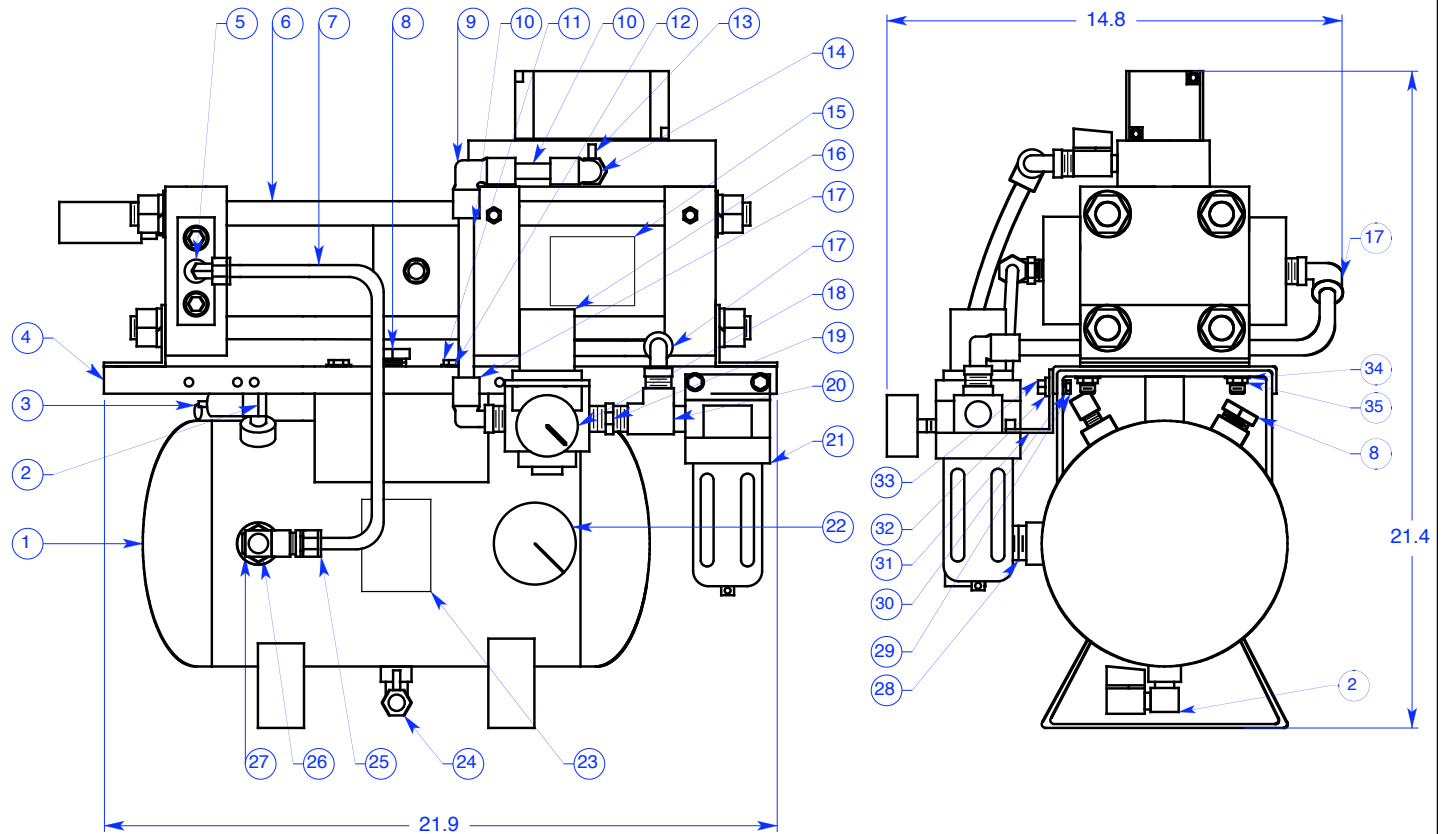

| | | | | |
|--|------------|--|--------|--|
| UNLESS OTHERWISE SPECIFIED DIMENSIONS ARE IN INCHES TOLERANCES ON: 2 PL DECIMALS +/- 0.01 3 PL DECIMALS +/- 0.003 ANGLES +/- 0.5° FRACTIONS +/- 1/16 | SIGNATURES | | DATE | MPS Midwest Pressure Systems, Inc. MIDWEST PRESSURE SYSTEMS 204 Easy Street • Carol Stream, IL 60188 5:1 Air Booster System |
| | DRAWN JEC | | 6/8/05 | |
| | CHECKED | | | |
| | ENGRG | | | |
| MATERIAL: | ISSUED JEC | | 6/8/05 | DWG NO S4020A3 REV |
| | | | | |
| SCALE | | | SHEET | |